

Keypad Access Control



1. Description

The device is a standalone access control and proximity card reader which supports EM & MF card types. It builds-in STC microprocessor, with strong anti-interference ability, high security and reliability, powerful function and convenient operation. It's widely used in high-end buildings, residential communities and other public places.

2. Features

Ultra-low Power	Standby current is less than 30mA
Wiegand Interface	WG26 or WG34 input and output
Searching time	Less than 0.1s after reading card
Backlight keypad	Operate easily at night
Doorbell interface	Support external wired doorbell
Access ways	Card, Pin code, Card & Pin code
Independent codes	Use codes without related card
Change codes	Users can change codes by themselves
Delete users by card No.	The lost card can be delete by keyboard

3. Specifications

Working Voltage: DC12-24V	Standby Current: ≤30mA
Card Reading Distance: 1~3cm	Capacity: 2000 users
Working Temperature: -40°C~60°C	Working Humidity: 10%~90%
Lock output load: ≤3A	Door Relay time: 0~99S (Adjustable)

4. Installation

Drill hole according to the size of the device and fix the back shell with the equipped screw. Thread the cable through the cable hole. connect the wires according to your required function, and wrap the unused wires to avoid short circuit. After connecting the wire, install the machine. (as show below)

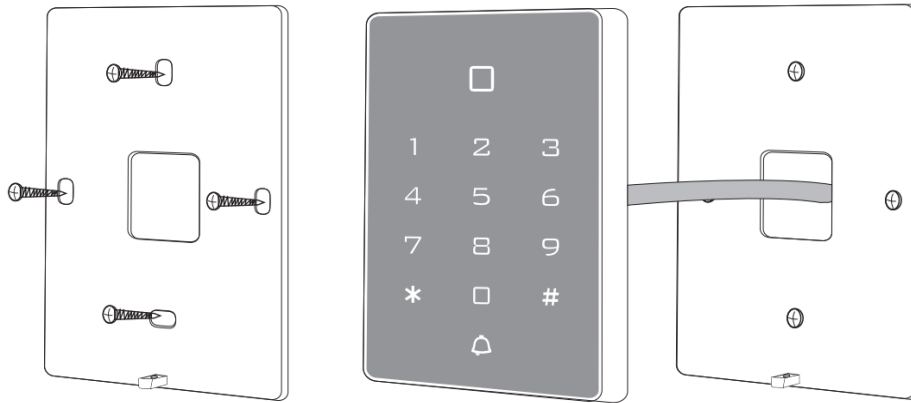

5. Wiring

Color	ID	Description
Green	D0	Wiegand Input(Wiegand Output in Card Reader Mode)
White	D1	Wiegand Input(Wiegand Output in Card Reader Mode)
Yellow	OPEN	Exit Button input terminal
Red	+12V	12V + DC Regulated Power Input
Black	GND	12V - DC Regulated Power Input
Blue	NO	Relay normally-on terminal
Purple	COM	Relay Public terminal
Orange	NC	Relay normally-off terminal
Pink	BELL_A	Doorbell button one terminal
Pink	BELL_B	Doorbell button to the other terminal

6.1 Diagram

Common Power Supply

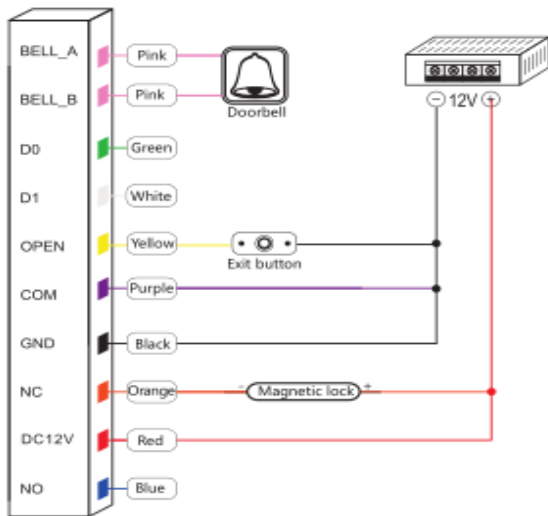

6.2 Special Power Supply

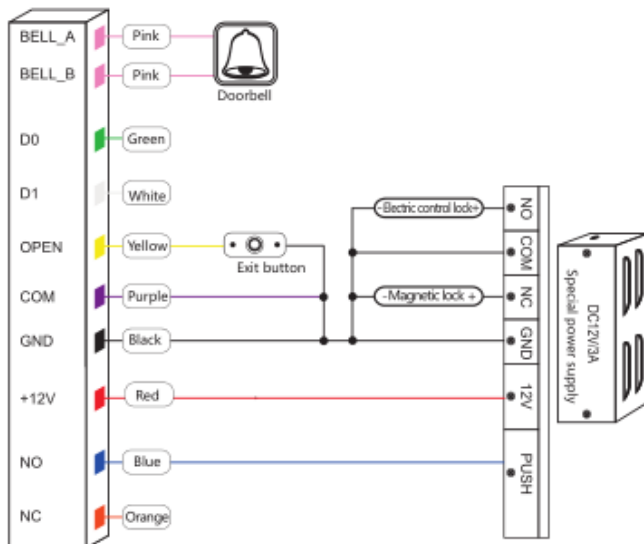

6.3 Reader Mode

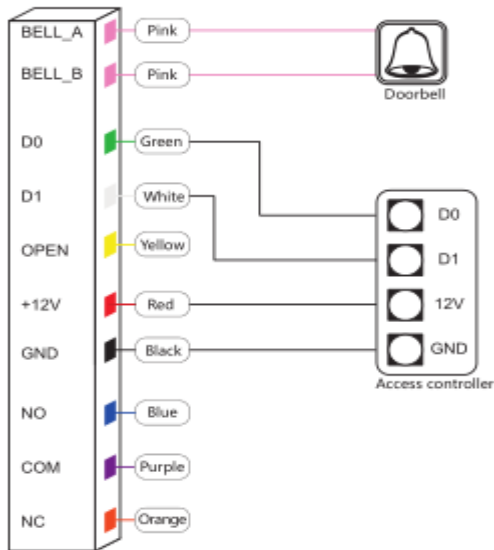

7. Sound & Light indication

Operate Status	LED Light Color	Buzzer
Standby	Red	
Keypad		Beep
Operation Successful	Green	Beep—
Operation Failed		Beep-Beep-Beep
Entering into Programming	Flash Red Slowly	Beep—
Programmable Status	Orange	
Exit Programming	Red	Beep—
Door Opening	Green	Beep—

8. Advance setting

	Change master code	Notes
0	Change Master code [*] [Master code] [#] [0] [New code] [#] [New code] [#]	Default factory master code is 999999.
1	Add Users	
	Add card [*] [Master code] [#] [1] [Read card] [#] ...[#]	Cards can be added continuously
	Add card number [*] [Master code] [#] [1] [8 digits or 10 digits] [#]	Card number can be added continuously
	Add ID number+card [*] [Master code] [#] [1] [ID number] [#] [Read card] [#]	Add user with specify ID number, easily find and delete.
	Add ID number+card number [*] [Master code] [#] [1] [ID number] [#] [8 digits or 10 digits] [#]	Add user with specify ID number, easily find and delete.
	Add PIN code [*] [Master code] [#] [1] [ID number] [#] [4 digits] [Pin code] [#]	ID number is from 1-1000
2	Delete Users	

	Delete card	* Master code # 2 Read card or 8 digits or 10 digits #	Cards can be deleted continuously
	Delete ID number	* Master code # 2 ID number #	When the card is broken or lost, you can delete the user by ID number
	Delete ALL users	* Master code # 2 0000 #	Delete ALL PIN code & card users except public PIN code.
3	Access ways		
	By card	* Master code # 3 0 #	Only the card user could unlock the door, keypad is invalid
	By card+PIN code	* Master code # 3 1 #	To enable this function, the user PIN code has to be changed.
	By card or PIN code	* Master code # 3 2 #	Both card user and PIN user could unlock the door (factory default)

4	Relay Output Delay Time		
	Door relay strike time	* Master code # 4 0~99 #	Door opening time range: 0-99s Default 5s
5	Working modes		
	Standalone access control mode	* Master code # 5 0 #	The door will be locked automatically after open the door normally
	Relay toggle mode	* Master code # 5 1 #	The door will not be locked automatically. To lock the door, the user has to read the card or press the exit button.
	Reader mode	* Master code # 5 2 26/34 #	WG26/34 input and output
6	Bind a code to a specific card	* Master code # 6 Read card 4 digits code #	When using card+code to unlock the door, it works under card+PIN mode(* Master code # 3 1 #)
7	<p>Example: Backup the data of machine A to machine B</p> <p>The green wire and white wire of machine A connects with the green wire and white wire of machine B correspondingly, set B for receiving mode at first, then set A for sending mode, the indicator light turns green flash during the data backup, data backup is successful when indicator light turns red.</p>		

	Data backup output	* [Master code] # [70] #	Send the data to external device.
	Data backup input	* [Master code] # [71] #	The device will receive the data.
*	Change the code by user card	* [Read card] [New code] # [Repeat new Code] # Note: card has to be registered, it works under card+PIN mode (* [Master code] # [31#])	
	Change the code by ID number added	* [ID NO.] # [Old code] # [New code] # [Repeat New code] # Note: All of same codes will be modified .	
	Reset to Factory Default	Power off, press the exit button continuously, power on, hearing beep sound twice, meanwhile, the indicator light turns orange, swipe the first card as for master add card, swipe the second card as for the master delete card, the master code has been reset to 999999, factory default settings are successful. ★Registered user data won't be deleted when reset to factory default	

9 Master Card Operation

9.1 Add Card

[Read master add card] [Read the 1st user card] [Read the 2nd user card] ... [Read master add card]

Note: The master add card is used to add card users continuously and quickly. When you read the master add card at the first time, you will hear short "BEEP" sound twice and the indicator light turns orange, it means you have entered into add user programming. When you read the master add card at the second time, you will hear long "BEEP" sound once and the indicator light turns red, it means you have exited the add user programming.

9.2 Delete Card

[Read master delete card] [Read the 1st user card] [Read the 2nd user card] ... [Read master delete card]

Note: The master delete card is used to delete card users continuously and quickly. When you read the master delete card at the first time, you will hear short "BEEP" sound twice and the indicator light turns orange, it means you have entered into delete user programming. When you read the master delete card at the second time, you will hear long "BEEP" sound once, the indicator light turns red, it means you have exited the delete user programming.